

Turbocharger Installation Instructions

⚠ ATTENTION! ⚠

Please follow the installation instructions. Damage resulting from incorrect installation of the product is not covered by the warranty.

Step 1

Check the air intake system and collector, if it's clean and free from debris.

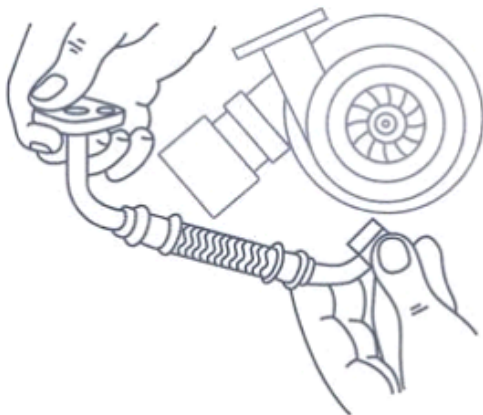
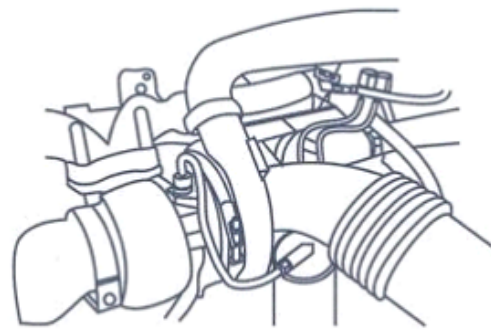

Step 2

Check if:

- the oil feed and drain lines are clean and undamaged,
- the oil feed line is not too close to the source of heat or if the heat shield is undamaged.

If necessary, clean or replace the oil lines with new ones.

Step 3

Refill engine with new engine oil, use new oil and fuel filters (refer to engine/vehicle manufacturer's literature).

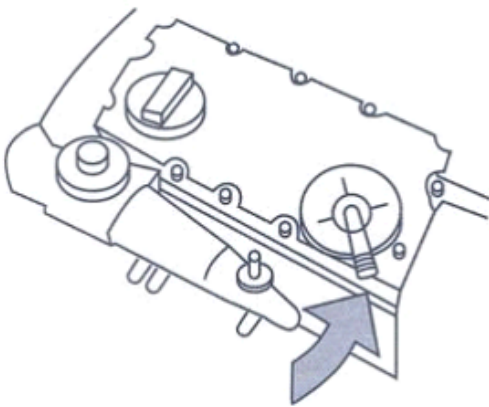

Step 4

Clean engine breather system and check function.

Step 5

Fit the turbo using a new gasket kit, liquid gasket or sealants are not recommended!

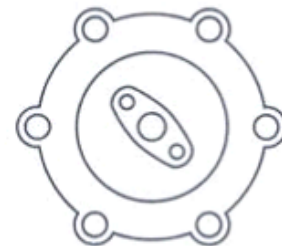
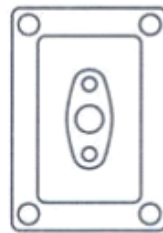

Step 6

Check the condition of exhaust manifold (it must be clean and undamaged), nuts/bolts.

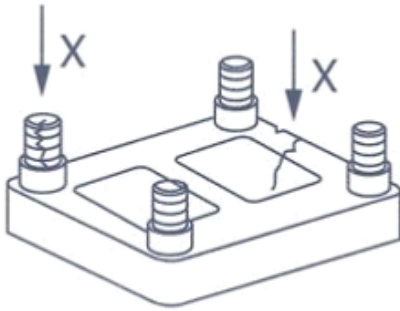

Step 7

Adjust the position of the housings. Make sure all the gaskets are new, tighten all the hoses.



Step 8

Using bolts of sufficient specification, fit the turbocharger onto the manifold or engine block. Tighten all nuts/bolts.

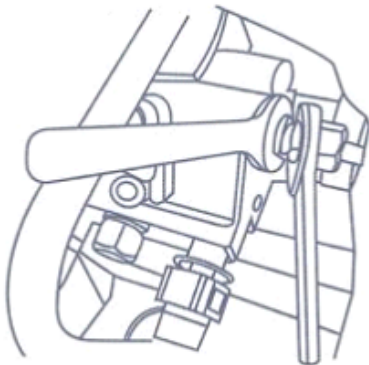

Step 9

Fit oil drain line. Refill the oil inlet hole with new clean engine oil and spin the compressor wheel by hand a few times.

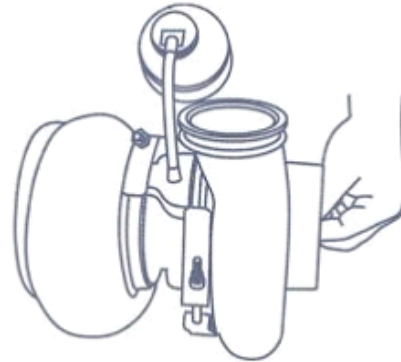

Step 10

Fit other hoses to the turbo.



Step 11

If possible, prevent the engine from firing and crank the engine for 10-15 seconds to prime oil feed.

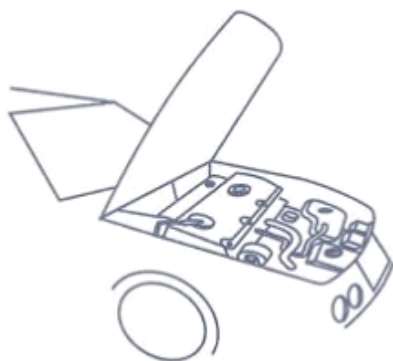

Step 12

Start the engine and idle for 3-4 minutes before increasing speed.

Step 13

Check for oil and gas/air leaks.

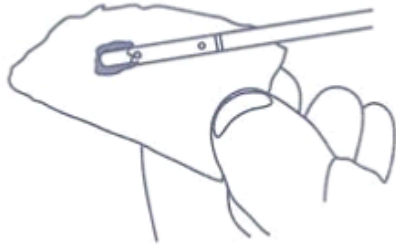

Step 14

Stop engine and re-check engine oil level.